Mixer Design Using SpectreRF Application Note

Product Version 5.0
December 2003
June 2004

© 2003-2004 Cadence Design Systems, Inc. All rights reserved.
Printed in the United States of America.

Cadence Design Systems, Inc., 555 River Oaks Parkway, San Jose, CA 95134, USA

Trademarks: Trademarks and service marks of Cadence Design Systems, Inc. (Cadence) contained in this document are attributed to Cadence with the appropriate symbol. For queries regarding Cadence's trademarks, contact the corporate legal department at the address shown above or call 800.862.4522.

All other trademarks are the property of their respective holders.

Restricted Print Permission: This publication is protected by copyright and any unauthorized use of this publication may violate copyright, trademark, and other laws. Except as specified in this permission statement, this publication may not be copied, reproduced, modified, published, uploaded, posted, transmitted, or distributed in any way, without prior written permission from Cadence. This statement grants you permission to print one (1) hard copy of this publication subject to the following conditions:

1. The publication may be used solely for personal, informational, and noncommercial purposes;
2. The publication may not be modified in any way;
3. Any copy of the publication or portion thereof must include all original copyright, trademark, and other proprietary notices and this permission statement; and
4. Cadence reserves the right to revoke this authorization at any time, and any such use shall be discontinued immediately upon written notice from Cadence.

Disclaimer: Information in this publication is subject to change without notice and does not represent a commitment on the part of Cadence. The information contained herein is the proprietary and confidential information of Cadence or its licensors, and is supplied subject to, and may be used only by Cadence's customer in accordance with, a written agreement between Cadence and its customer. Except as may be explicitly set forth in such agreement, Cadence does not make, and expressly disclaims, any representations or warranties as to the completeness, accuracy or usefulness of the information contained in this document. Cadence does not warrant that use of such information will not infringe any third party rights, nor does Cadence assume any liability for damages or costs of any kind that may result from use of such information.

Restricted Rights: Use, duplication, or disclosure by the Government is subject to restrictions as set forth in FAR52.227-14 and DFAR252.227-7013 et seq. or its successor.

Contents

<u>Mixer Design Measurements</u>	5
<u>Purpose</u>	5
<u>Audience</u>	5
<u>Overview</u>	5
<u>Introduction to Mixers</u>	5
<u>The Design Example: A Differential Input Mixer</u>	6
<u>Testbench and Measurements</u>	7
<u>Example Measurements Using SpectreRF</u>	8
<u>Conversion Gain</u>	8
<u>Voltage Conversion Gain Versus LO Signal Power (Swept PSS with PAC)</u>	9
<u>Voltage Conversion Gain Versus RF Frequency (PSS and Swept PAC)</u>	11
<u>Voltage Conversion Gain Versus RF Frequency (PSS and Swept PXF)</u>	13
<u>Power Conversion Gain Versus RF Frequency (QPSS)</u>	15
<u>Power Dissipation (QPSS)</u>	16
<u>S-Parameters (PSS and PSP)</u>	18
<u>Total Noise and NF, SSB and DSB Noise Figures (PSS and Pnoise)</u>	21
<u>Intermodulation Distortion and Intercept Points (Swept QPSS and QPAC)</u>	25
<u>Port-to-Port Isolation Among RF, IF and LO Ports (PSS and Swept PAC)</u>	28
<u>Mixer Performance with a Blocking Signal (QPSS, QPAC, and QPNoise)</u>	32

Mixer Design Using SpectreRF

Mixer Design Measurements

The procedures described in this application note are deliberately broad and generic. Your specific design might require procedures that are slightly different from those described here.

Purpose

This application note describes how to use SpectreRF in the Analog Design Environment to measure parameters which are important in design verification of mixers.

Audience

Users of SpectreRF in the Analog Design Environment.

Overview

This application note describes a basic set of the most useful measurements for mixers.

Introduction to Mixers

Mixers are key components in both receivers and transmitters. Mixers translate signals from one frequency band to another. The output of the mixer consists of multiple images of the mixers input signal where each image is shifted up or down by multiples of the local oscillator (LO) frequency. The most important mixer output signals are usually the signals translated up and down by one LO frequency.

In an ideal situation, the mixer output would be an exact replica of the input signal. In reality mixer output is distorted due to non-linearity in the mixer. In addition, the mixer components and a non-ideal LO signal introduce more noise to the output. Bad design might also cause leakage effects, complicating the design of the complete system.

Noise performance and rejection of out-of-band interferers are both critical to the receiver system because they both limit the receiver system's sensitivity. Linearity is important to transmitter performance, where you want an error-free output signal.

Mixer Design Using SpectreRF

Mixer Design Measurements

The example circuit, a single balanced differential down-converting mixer, runs with a local oscillator at $f(LO) = 5$ GHz. The range of interest is baseband output noise from 1 kHz to 10 MHz. The RF signal frequency used for the simulation is around 5001 MHz.

Testbench and Measurements

Use the mixer measurements testbench shown in Figure 1-2 to measure typical mixer characteristics. Use a PORT component and match an impedance for each of the inputs and the output.

- To supply a LO input to the mixer, use a port (*PORT1*) with a matching resistor and transfer the single-ended signal into the differential with an ideal passband balun.
- To represent the RF input to the mixer, use a port (*PORT0*) which is matched with the mixer input.
- To use the differential output for measurements, match the output port (*PORT3*) to the output impedance of the mixer.

Simulate the resulting testbench as follows

- Set the LO bias voltage to 1.5 V and the mixer supply of 2.5 V.
- Set the LO port to *sinusoidal* source for all the measurements described in this application note.
- Set the RF port to either *dc* or *sinusoidal* source, depending on the requirements of each measurement. When the RF port is set to *dc* source it has a DC bias of 0.5 V.
- For both LO and RF ports, the amplitude and frequency of the signal are parametrized as *plo*, *prf* and *frf*. You usually specify the amplitude in dBm. In addition, for the RF port specify the small signal parameter *PAC Magnitude*. Use *pacmag* or *pacdbm*, depending on the units you prefer.
- Set the Output Port to *dc* with no bias.

Note: To edit port characteristics, select the port in the schematic. Then choose *Edit—Object—Properties* and make your changes in this form.

Mixer Design Using SpectreRF Mixer Design Measurements

Figure 1-2 Testbench for Mixer Measurements

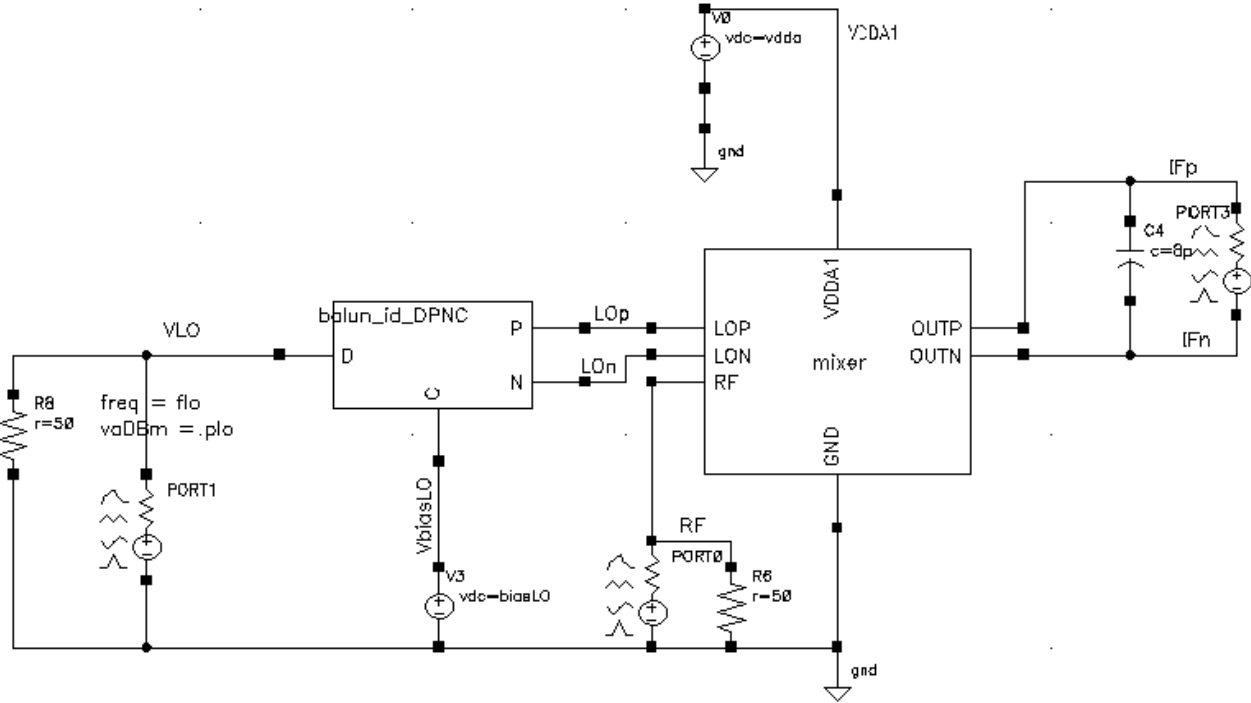

Important

In a particular design investigation where a perfectly balanced design is simulated, the results might be too optimistic. To make the measurements more realistic, investigate the effects of the real silicon on the parameters in the circuit and include those variations. For example, you might use a parametric sweep.

Example Measurements Using SpectreRF

The mixer measurements described in the following sections are calculated using SpectreRF in the Analog Design Environment.

Conversion Gain

A mixer's frequency converting action is characterized by conversion gain or loss.

- The *voltage conversion gain* is the ratio of the RMS voltages of the IF and RF signals.

Mixer Design Using SpectreRF

Mixer Design Measurements

- The *power conversion gain* is the ratio of the power delivered to the load and the available RF input power.

When the mixer's input impedance and load impedance are both equal to the source impedance, the power and voltage conversion gains, in decibels, are the same. Note that when you load a mixer with a high impedance filter, this condition is not satisfied.

You can calculate the voltage convergence gain in two ways:

- Using a small-signal analysis, like PSS with PAC or PXF. The PSS with PAC or PXF analyses supply the small-signal gain information. You can use either PAC or PXF analysis to compute the voltage gain.
- Using a two-tone large-signal QPSS analysis which is more time-consuming.

The power convergence gain, in general, requires that you run the two-tone large-signal QPSS analysis.

Voltage Conversion Gain Versus LO Signal Power (Swept PSS with PAC)

This example measures the variation of conversion gain with the power of the LO signal.

Testbench:

Mixer testbench in Figure [1-2](#).

Stimuli:

Modify the RF port by setting *Source Type* to *dc*. The only large signal is from the *plo* port.

Parameters:

Set the parameters *pacmag* = 1 and *plo* = 0.

Simulation/Analyses:

1. Set up a swept PSS analysis.

Set the *fundamental frequency* parameter, *flo* = 5 GHz. Set *errpreset* = *moderate*. Click *Sweep* and enter *plo* as the *Variable Name* parameter to sweep LO power. Click *Sweep Range* and set *Start* = -10 dBm and *Stop* = 20 dBm. This sweeps LO power from a small value to a value above the expected gain saturation.

Mixer Design Using SpectreRF

Mixer Design Measurements

2. Set up a PAC analysis:

Set *fixed input frequency point* to the RF signal frequency, 5001 MHz. Select *sidebands* either by specifying *Maximum sidebands = 2* or using *Select from range*. Set the maximum sideband to 2 as you are only interested in the first harmonics of LO.

Note: Setting *Maximum sidebands = 2* is good for this example, other circuits might require a different value.

3. Run the simulations.

Display/Data Analyses:

Click *Results—Direct Plot—Main Form*. Click *pac* analysis and select *Sweep* as *variable*. Select *Voltage Gain* with *dB20* for the *Modifier*. Select the RF port (*PORT3*) as an *Instance with 2 Terminals*.

Important

The PAC analysis computes gain directly *only* when you set the *pacmag* parameter to 1 V. Otherwise, take a ratio of the output and input.

Mixer Design Using SpectreRF

Mixer Design Measurements

Figure 1-3 Conversion Gain Versus LO Power Using PAC Analysis

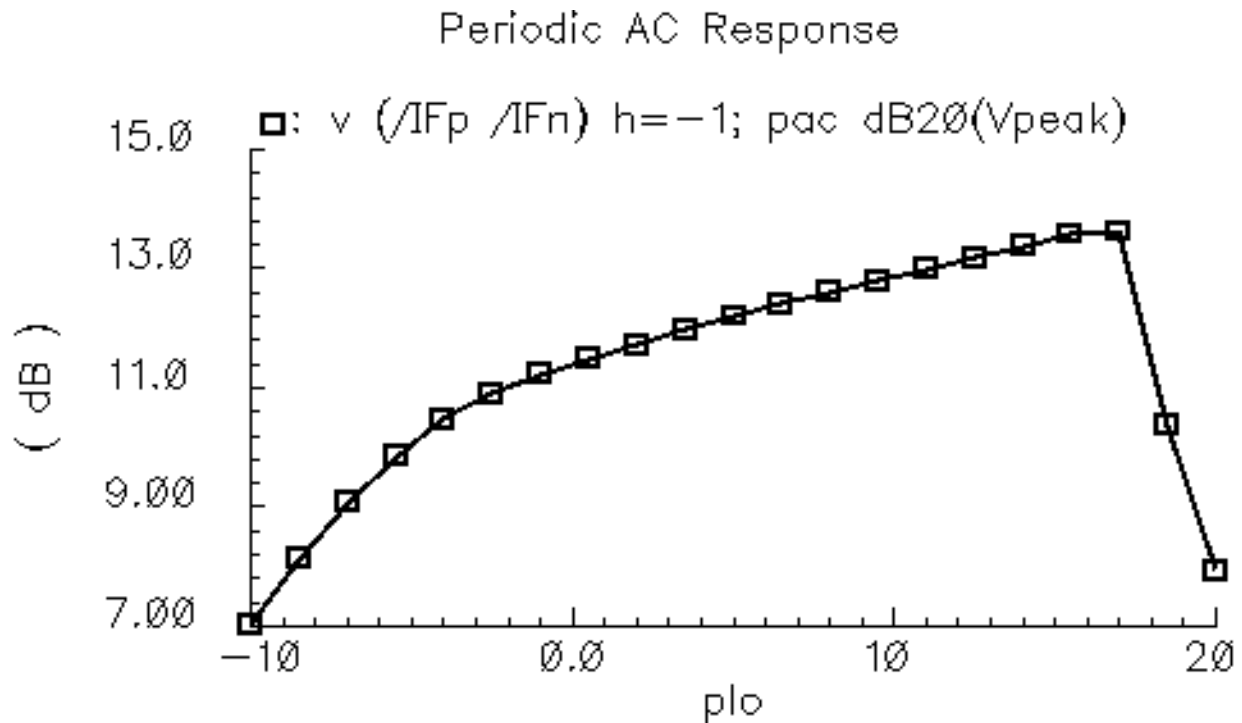

Important

The maximum conversion gain value is reached somewhere above 15 dBm. Use this value for the *p1o* parameter in the following measurements. (See the first step in the next example.)

Voltage Conversion Gain Versus RF Frequency (PSS and Swept PAC)

This example measures how conversion gain varies with the frequency of the stimuli.

Testbench:

Mixer testbench in Figure [1-2](#).

Simulation/Analyses:

1. Set up a PSS analysis.

Mixer Design Using SpectreRF

Mixer Design Measurements

Set the *fundamental frequency* parameter, $f_{lo} = 5$ GHz. Set $errpreset = moderate$. Set LO power to $p_{lo} = 15$. (This is the value you read off the plot in Figure 1-3.)

2. Set up a swept PAC analysis:

Set the RF input frequency to sweep from 5 G + 1 kHz to 5 G + 10 MHz. Select *sidebands* either by specifying *Maximum sidebands* = 2 or using *Select from range*.

Note: Setting the *Maximum sidebands* = 2 is good for this example, other circuits might require a different value.

3. Run the simulations.

Display/Data Analyses:

Click *Results—Direct Plot—Main Form*. Click *pac* analysis. Click *Voltage Gain* and select *dB20* for *Modifier*. Select the RF port (*PORT3*) on the schematic. The Conversion Gain plot in Figure 1-4 displays.

Figure 1-4 Conversion Gain Versus Input Frequency Using Swept PAC Analysis

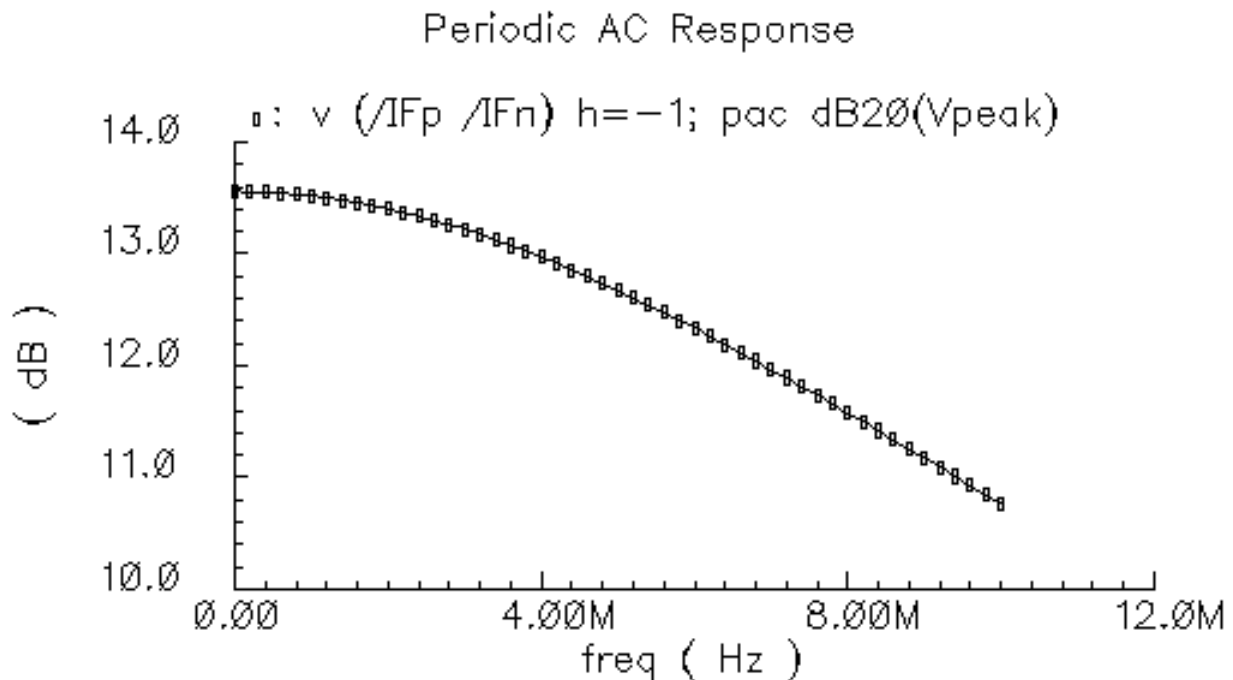

Mixer Design Using SpectreRF

Mixer Design Measurements

Important

Since the *sweep type* in the analysis was *linear* by default, uniform frequency points display along the X-axis in Figure [1-4](#). For a large frequency range, set the *sweep type* to *logarithmic* as it is by default in [Figure 1-5](#) on page 14.

Important

The same PAC analysis generates results you can use to measure RF to LO isolation and will be used in measurements that follow.

Voltage Conversion Gain Versus RF Frequency (PSS and Swept PXF)

This example measures the small-signal voltage conversion gain using the PXF analysis.

Testbench:

Mixer testbench in [Figure 1-2](#).

Simulation/Analyses:

1. Set up a PSS analysis:

Set the *fundamental frequency* parameter, $f_{lo} = 5$ GHz. Set *errpreset* = *moderate*. Set LO power to $p_{lo} = 15$. (This is the value you read off the plot in [Figure 1-3](#).)

2. Set up a swept PXF analysis.

Sweep the output frequency from 1 kHz to 10 MHz. Select sidebands either by specifying *Maximum sidebands* = 2 or using *Select from range*.

Note: Note that *Maximum sidebands* = 2 is good for this example, other circuits might require a different value.

Set the Output to the RF port by specifying output as *Voltage* with *Positive Output Node* being the *Pif* net and *Negative Output Node* being the ground.

3. Run the simulations.

Mixer Design Using SpectreRF

Mixer Design Measurements

Display/Data Analyses:

Click *Results—Direct Plot—Main Form*. Click *pxf* analysis. Click *Voltage Gain*. Select *dB20* for *Modifier*, Select the RF port (*PORT0*) on the schematic. The Conversion Gain plot in Figure 1-5 displays.

The *sweep type* in the analysis is *logarithmic* by default, which explains the difference in the X-axes between Figures 1-4 and 1-5. The large frequency range in Figure 1-5 requires a *logarithmic* X-axis.

The same PXF analysis generates results you can use to measure LO -to-IF isolation versus frequency as in “Port-to-Port Isolation Among RF, IF and LO Ports (PSS and Swept PAC)” on page 28.

Figure 1-5 Conversion Gain Versus Input Frequency Using PXF Analysis

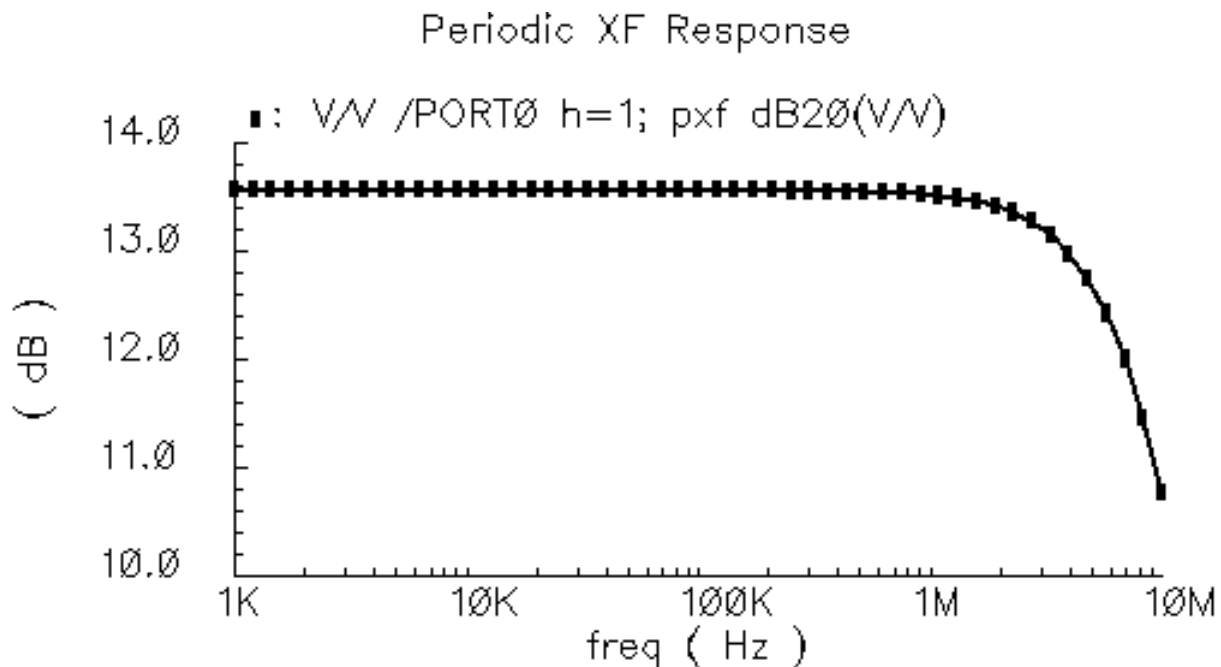

Other Ways to Measure Gain

Yet another way to measure small-signal gain is to use the PSS and PSP analyses to get the gain and noise parameters with one simulation.

You can also set up an appropriate QPSS analysis to measure large-signal gain. Set LO as a large tone on the *Plo* port. Use a sinusoidal voltage source for the *Prf* port. This analysis

Mixer Design Using SpectreRF

Mixer Design Measurements

models the signal at a particular frequency going through the mixer. In the Direct Plot form for QPSS, the *Voltage* and *Power Gain* provide all the needed information.

Power Conversion Gain Versus RF Frequency (QPSS)

You can measure the Power Conversion Gain for an unmatched source and load using a QPSS analysis. Details of the QPSS analysis setup are the same as in "[Power Dissipation \(QPSS\)](#)" on page 16. Set the RF signal as a second moderate tone and use its frequency as a swept parameter in the QPSS analysis. The Resulting Power Gain is displayed in Figure 1-6.

Figure 1-6 Power Gain Using QPSS Analysis

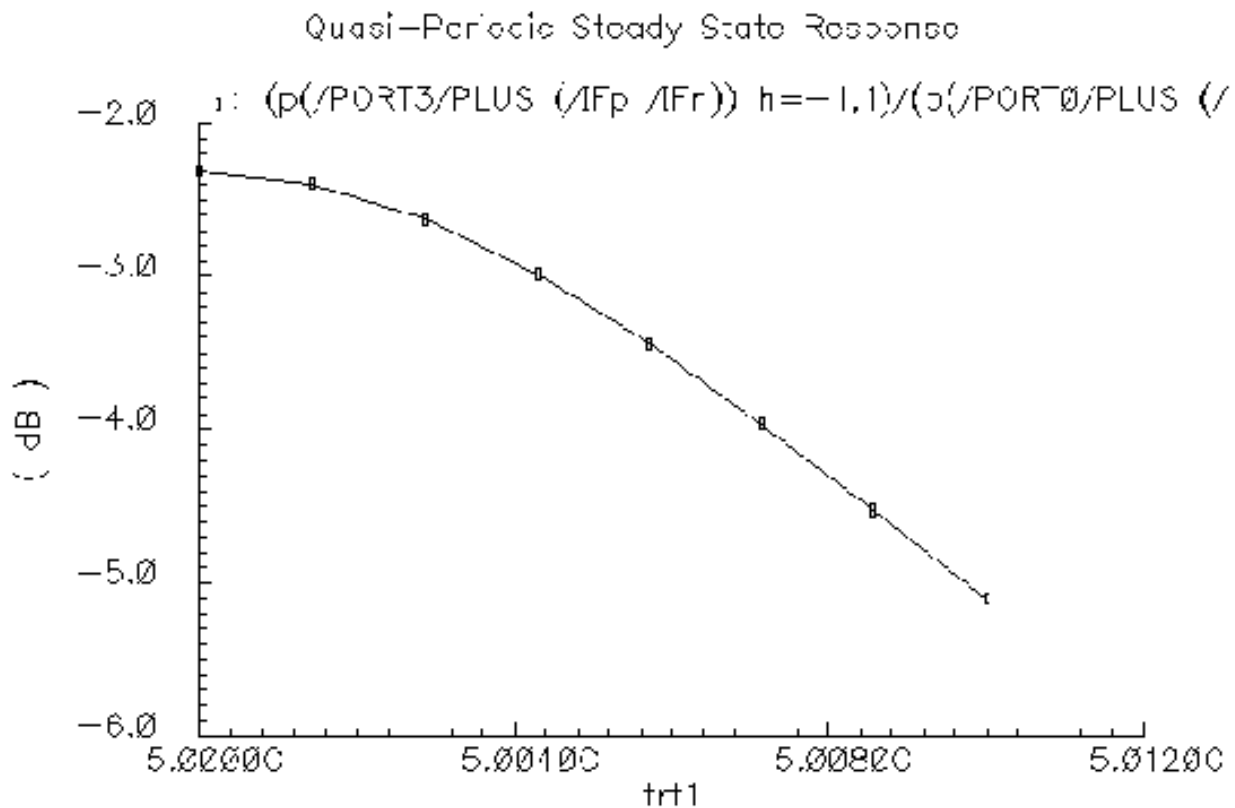

Mixer Design Using SpectreRF

Mixer Design Measurements

Power Dissipation (QPSS)

Measure power dissipation using the large-signal QPSS analysis. If the effect of the RF tone is small, you might use a PSS analysis instead, as mentioned in previous sections.

The QPSS and PSS analyses provide only spectrum data, not a scalar value, of the total power. To get a scalar value for total power, work through the summation over the harmonics and sidebands. In general, most of the power is in the main output harmonics.

Note: Some users might not be fully aware of the notion of the port and they might get wrong results by relying on a 50 Ohm resistance for the port. To get the correct results for unmatched ports, you need to save the currents on the power supply terminals.

Simulation Analyses:

1. Set up a QPSS analysis.

Set LO as a large tone with $f_{lo} = 5$ GHz. Set RF as a moderate tone with $f_{rf} = 5.01$ GHz. Set *errpreset* to *moderate* or *liberal*. Set LO power to $p_{lo} = 15$. Set RF power to $p_{rf} = -30$.

Properly select the maximum harmonics for each tone. For moderate tones, carefully select maximum harmonic values as they affect performance. Limit the maximum harmonic value to the maximum index of interest plus one more. For this example, set LO = 5 and RF = 3. You might select any reasonable number of LO harmonics since the large tone is modelled in the time domain and you can analyze up to 40 harmonics without runtime penalty.

2. Run the QPSS analysis.

Display/Data Analysis:

Click *Results-Direct Plot-Main Form*. Click *qpss* analysis. Click *Power* and plot the spectrum at the *VDD* power source. Set *Modifier* as *dB10*. The results display as in Figures [1-7](#) and [1-8](#).

Mixer Design Using SpectreRF

Mixer Design Measurements

Figure 1-7 Power Spectrum at the Power Source Using QPSS Analysis

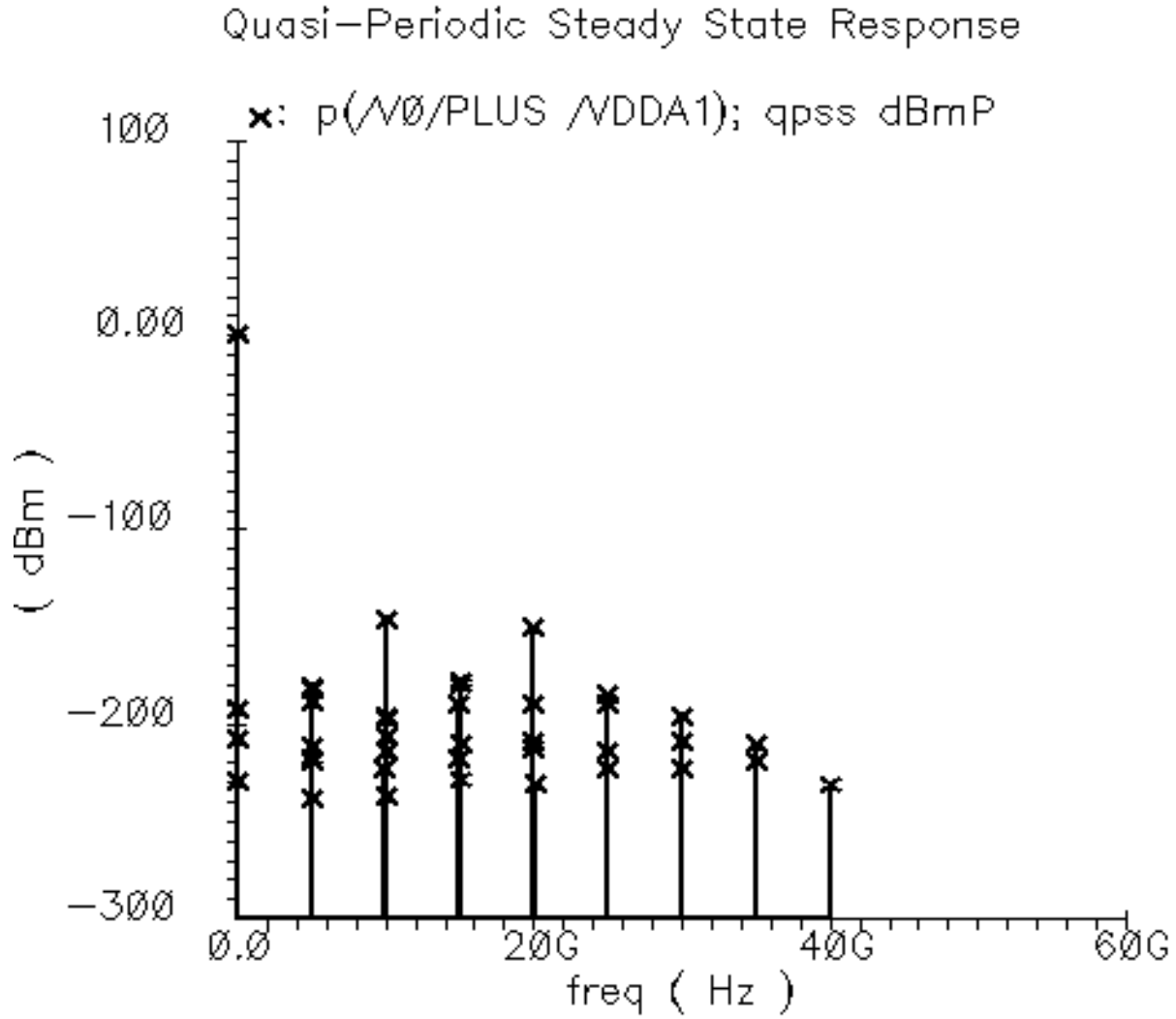

Mixer Design Using SpectreRF

Mixer Design Measurements

Figure 1-8 Power Spectrum at the Power Source Using QPSS Analysis

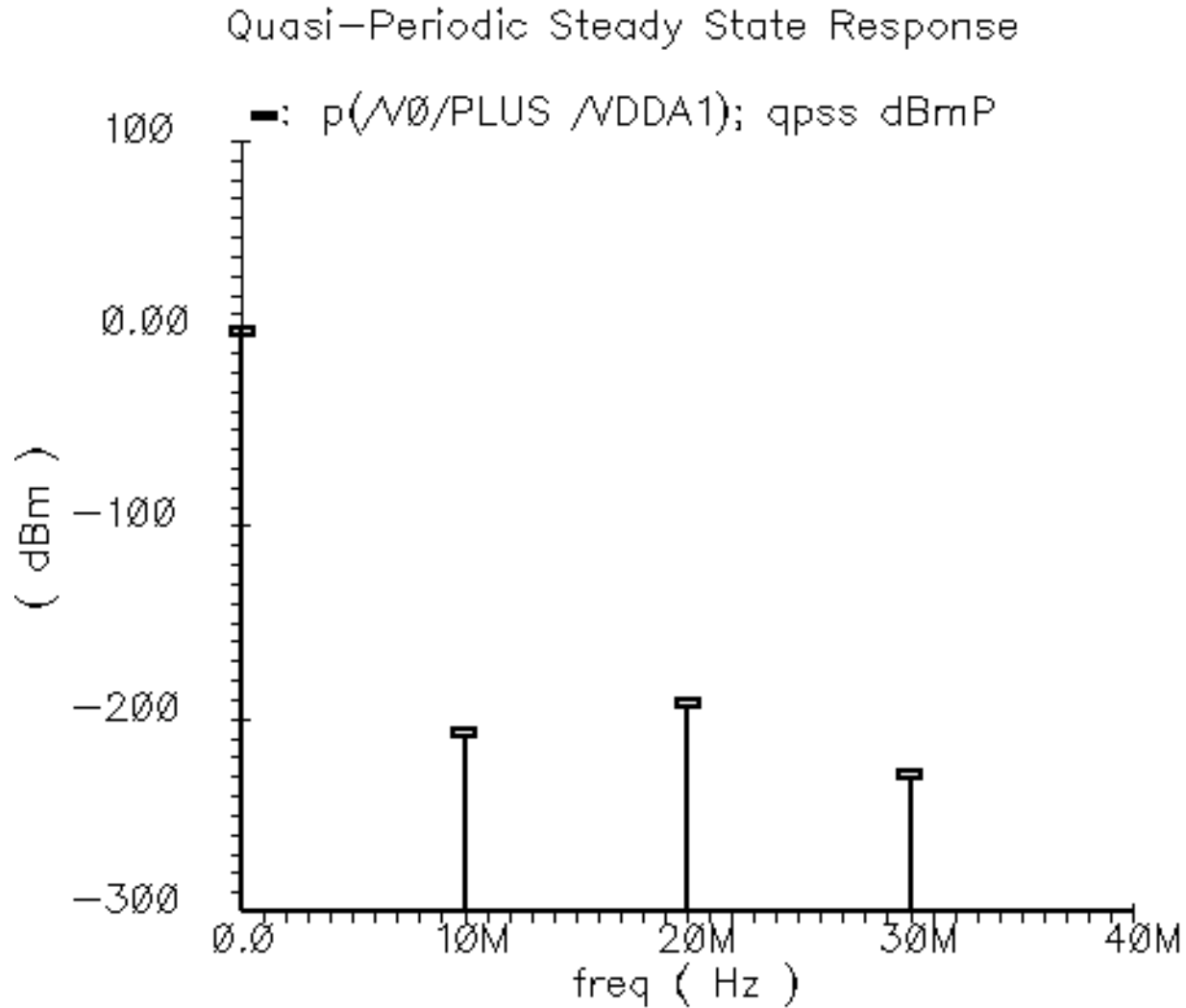

As expected most of the power comes from a limited number of harmonics, with only one harmonic being significant, which is the DC component for this type of mixer.

S-Parameters (PSS and PSP)

The receiver amplifies the small input signals to the point where they can be processed by the baseband section. You develop a gain budget where every stage in the receiver is assigned the gain it is expected to provide. Therefore, the signal gain or loss provided by the mixer must be known.

Mixer Design Using SpectreRF

Mixer Design Measurements

There are various ways of characterizing gain and all are derived from the mixer's S-parameters. As such, it must be easy to calculate the various S-parameters of the circuit and apply the various gain metrics.

Testbench:

Mixer testbench in Figure [1-2](#).

Simulation/Analyses:

1. Set up a PSS analysis.

Use the PSS analysis setup described in "[Voltage Conversion Gain Versus RF Frequency \(PSS and Swept PXF\)](#)" on page 13.

Set LO as a large-signal.

2. Set up a PSP analysis:

In the PSP Choosing Analysis form, set up the frequency sweep and the physical ports of interest, *PORT0*, *PORT3* and *PORT1*. For convenience, the first and second ports are also called input and output ports in the noise computations. To select an appropriate harmonic for each port, start with the second port, *PORT3*, and set its harmonic to 0. Configure the remaining ports according to the frequency translation. Since the example involves downconversion, use 1 for the input RF port, *PORT0*. To observe an isolation from LO, set 1 for the LO port, *PORT1*.

3. Run the PSS and PSP simulations.

Mixer Design Using SpectreRF

Mixer Design Measurements

Figure 1-9 PSP Form for Measuring S-Parameters

Periodic S-Parameter Analysis

Sweeptype relative

Frequency Sweep Range(Hz)

Start-Stop Start Stop

Sweep Type

Automatic

Add Specific Points

Select Ports

Port#	Name	Harm.	Frequency
1	PORT0	1	5.000001G - 5.01G
2	PORT3	0	1K - 10M
3	PORT1	1	5.000001G - 5.01G

Do Noise

yes no

Maximum Sideband

Mixer Design Using SpectreRF

Mixer Design Measurements

The Direct Plot form provides many measurements, including noise parameters between the first and second ports as in Figure 1-10.

Figure 1-10 S-Parameters Using PSP Analysis

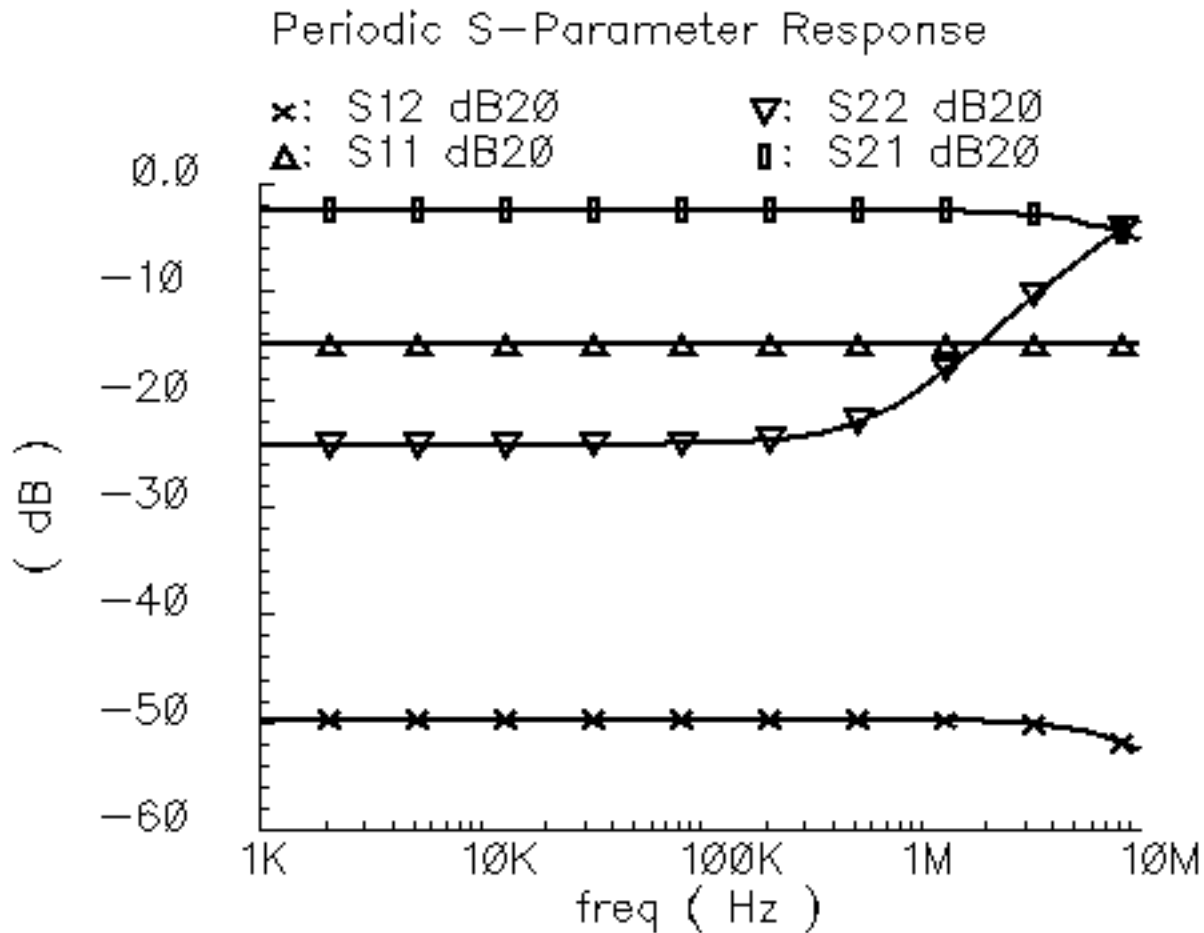

Note: If you are interested in the effect of a strong interferer on the mixer's S-parameters, run the QPSS and QPSP analyses. Set a moderate tone as the blocker frequency. This method is discussed in "[Mixer Performance with a Blocking Signal \(QPSS, QPAC, and QPNoise\)](#)" on page 32.

Total Noise and NF, SSB and DSB Noise Figures (PSS and Pnoise)

Noise from the mixer, as moderated by the LNA's gain, places a limit on how small a signal can be resolved that affects the sensitivity of the receiver. Noise is measured using the noise figure (NF), which is a measure of how much noise the mixer adds to the signal relative to the noise that is already present in the signal. A NF of 0 dB is ideal, meaning that the mixer adds

Mixer Design Using SpectreRF

Mixer Design Measurements

no noise. A NF of 3 dB implies that the mixer adds an amount of noise equal to that already present in the signal. For a mixer alone, a NF of 15 dB is typical.

Running the PSS and PNoise analyses produces all the needed information which includes total output noise and noise figure.

Testbench:

Mixer testbench in [Figure 1-2](#) on page 8.

Simulation and analyses:

1. Set up a PSS analysis.

Use the PSS analysis setup described in [“Voltage Conversion Gain Versus RF Frequency \(PSS and Swept PXF\)”](#) on page 13.

Also, set the RF port, *PORT0*, to have *Source type = dc*.

2. Set up a Pnoise analysis.

For the output to measure noise, use *voltage* and set the *Positive Output Node* to *Pif* Set the *Negative Output Node* to *ground*. Currently you can only use a *vsource*, an *isource* or a *port* for an input probe.

If the input source is noisy, as is the *port* for example, the noise analysis computes the noise factor (F) and noise figure (NF).

3. Run the PSS and Pnoise simulations.

Display/Data Analysis:

The Direct Plot form plots both single-sideband (SSB) and double-sideband (DSB) noise figure, as shown in [Figures 1-11](#) and [1-12](#). You can also plot output noise and other noise metrics.

Mixer Design Using SpectreRF

Mixer Design Measurements

Figure 1-11 Noise Figure Versus LO Power Using PNoise Analysis

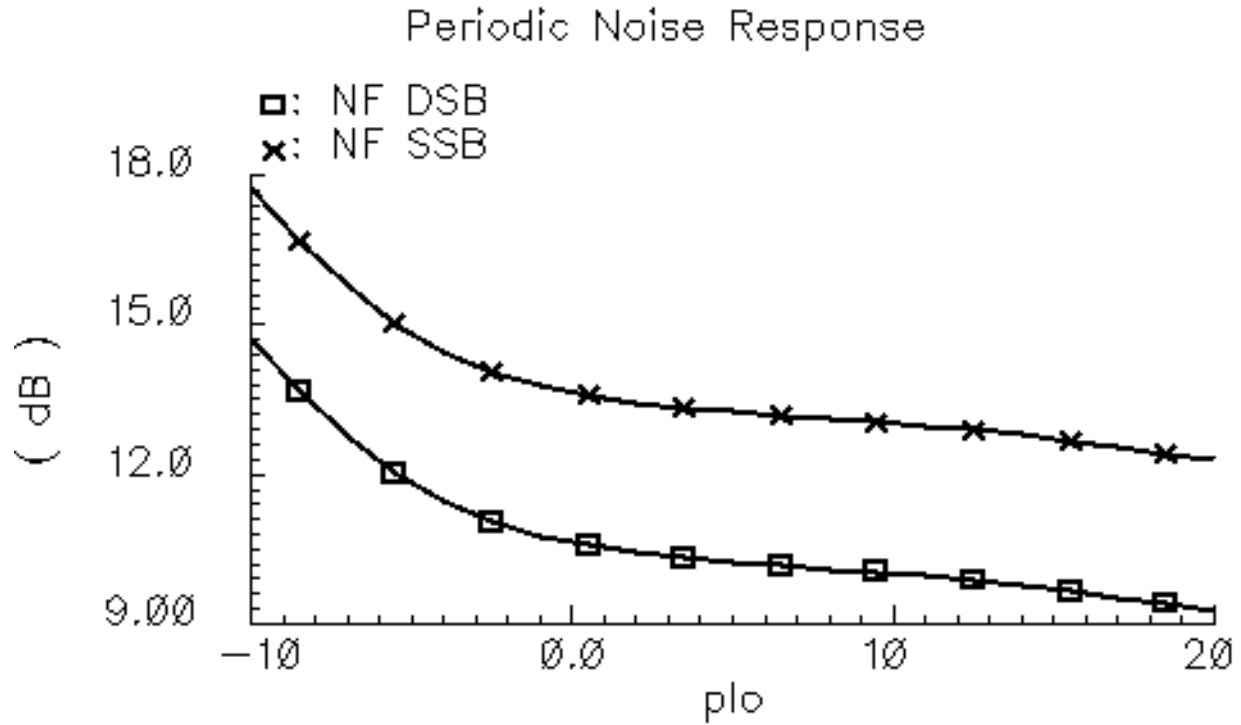

Mixer Design Using SpectreRF

Mixer Design Measurements

Figure 1-12 Noise Figure Versus LO Power Using PNoise Analysis

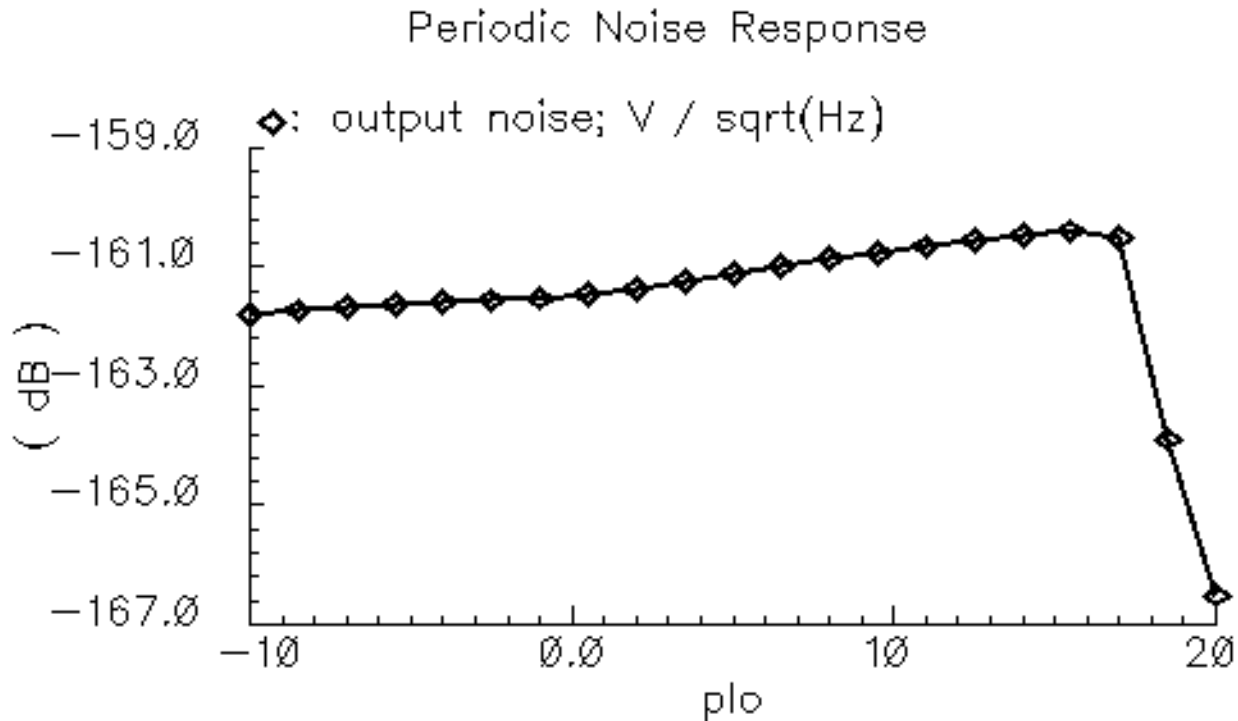

For input-referred noise, use either a *vsouce* or *isource* as the input probe. For noise figure, use a *port* as the input probe.

Important

You can find additional information in the *Noise Summary* which you can access by choosing *Results-Print*. If you require even more detail about the individual noise contributors, you can extract them. To do this, while setting up the Pnoise analysis, click *Options* in the Pnoise Choosing Analysis form and set *saveallsidebands = yes*.

You can also measure noise figure frequency variation by holding the LO power fixed and sweeping the frequency range, as described in [“Voltage Conversion Gain Versus RF Frequency \(PSS and Swept PAC\)”](#) on page 11.”

If you are not interested in detailed noise information, Pnoise analysis provides Noise Figure and other measurements when you specify the second output probe as the IF port. This gives you access to all the types of noise figure, noise correlation matrices and equivalent noise parameters.

Intermodulation Distortion and Intercept Points (Swept QPSS and QPAC)

Mixer distortion limits the sensitivity of a receiver if there is a large interfering signal present that is within the bandwidth of the RF input filter (a characteristic known as *selectivity*). There are two aspects of distortion that are of concern

- Compression
- Intermodulation Distortion

The 1 dB compression point (CP1) is the point where the output power of the fundamental crosses the line that represents the output power extrapolated from small-signal conditions minus 1 dB. The 3rd order intercept point (IP3) is the point where the third-order term as extrapolated from small-signal conditions crosses the extrapolated power of the fundamental. Both CP1 and IP3 are illustrated in Figure 1-13.

Figure 1-13 The 1 dB Compression and IP3

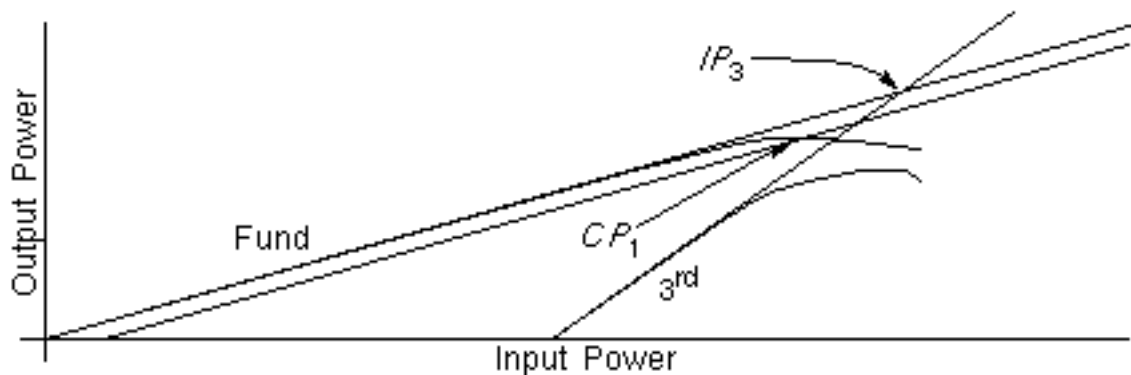

Intermodulation distortion occurs when signals at frequencies f_1 and f_2 mix together to form the response at $2f_1 - f_2$ and $2f_2 - f_1$. If f_1 and f_2 are close enough in frequency, then the intermodulation products $2f_1 - f_2$ and $2f_2 - f_1$ will be in-band and so will interfere with the reception of the input signal. (When choosing f_1 and f_2 , perform a PAC analysis to determine the bandwidth of the circuit, and place them in the middle of the bandwidth, close enough in frequency so that their intermodulation terms will also be well within the bandwidth.)

Distortion of the output signal occurs because several of the odd-order intermodulation tones fall within the bandwidth of the circuit.

Intermodulation distortion is typically measured in the form of an intercept point. As shown in Figure 1-13, you determine the 3rd order intercept point (IP3) by plotting the power of the fundamental and the 3rd order intermodulation product versus the input power. Both input and output power should be plotted in some form of dB. Extrapolate both curves from low power level and identify where they cross, that is the intercept point. To make this

Mixer Design Using SpectreRF

Mixer Design Measurements

determination and to be comfortable with the accuracy of the results, you must have a broad region where both curves follow their asymptotic behavior. When in the asymptotic region, the slope of an n th order distortion product will have a slope of n . Thus, when measuring IP3, the fundamental power curve is extrapolated from where the curve has a slope of 1 over a broad region. The 3rd order intermodulation product is extrapolated from a point where its curve has a slope of 3 over a broad region.

The recommended approach to predicting IP3 is to apply the LO and one medium RF tone, and perform a QPSS analysis. Then apply the second tone as a small tone close to the RF signal in frequency, and perform a QPAC analysis to compute IP3. The power of a small-signal, $pacmag$, has to be small enough so IM1 and IM3 are in their asymptotic ranges.

Testbench:

Mixer testbench in Figure [1-2](#).

Stimuli:

Apply a large sinusoidal signal at the LO port ($PORT1$). Use the RF port ($PORT0$) for a moderate sinusoidal source to model the second tone and set its *Source type* to *sine*. Parametrize the power of the second tone to be prf . Replace the parameter for *PAC Magnitude* with the parameter for *PAC Magnitude (dBm)* in the *Small Signal Parameters* section for the RF port ($PORT0$). In this example $pacm$ is used.

Simulation/Analyses:

1. Set up a swept QPSS analysis.

Set a large tone of 5 GHz $f(LO)$ and a moderate tone of 5.001 GHz $f(RF)$. Set up a calculation to output 5 harmonics on the large tone and 4 harmonics on the moderate tone. Set up the prf variable to sweep from -70 dB to -8 dB. Set $pacm$ equal to prf .

2. Set up a QPAC analysis.

Set the frequency of the small signal very close to $f(RF)$, for example 5.0011 GHz. In the *Select from range* option of the *Sidebands* section, highlight the harmonics of interest. Limit the harmonics to second order in the large tone (Set *Clock order* = 2), from 0 Hz to 6 GHz. The example does not use the 3rd harmonic of the moderate tone, so remove them from the list.

3. Run the swept QPSS and the QPAC simulations.

Mixer Design Using SpectreRF

Mixer Design Measurements

Display/Data Analysis:

Display results using the Direct Plot form.

To plot the 1 dB compression point, click *QPSS* analysis. Select *Compression Point*. Select a point in the linear region for an extrapolation. Select -50 dBm in this example. The RF output harmonic is (-1 1) or 1 MHz. After you select the output RF port, you see the value of CP1 as shown in Figure 1-14.

Figure 1-14 1dB Compression Point Using QPSS Analysis

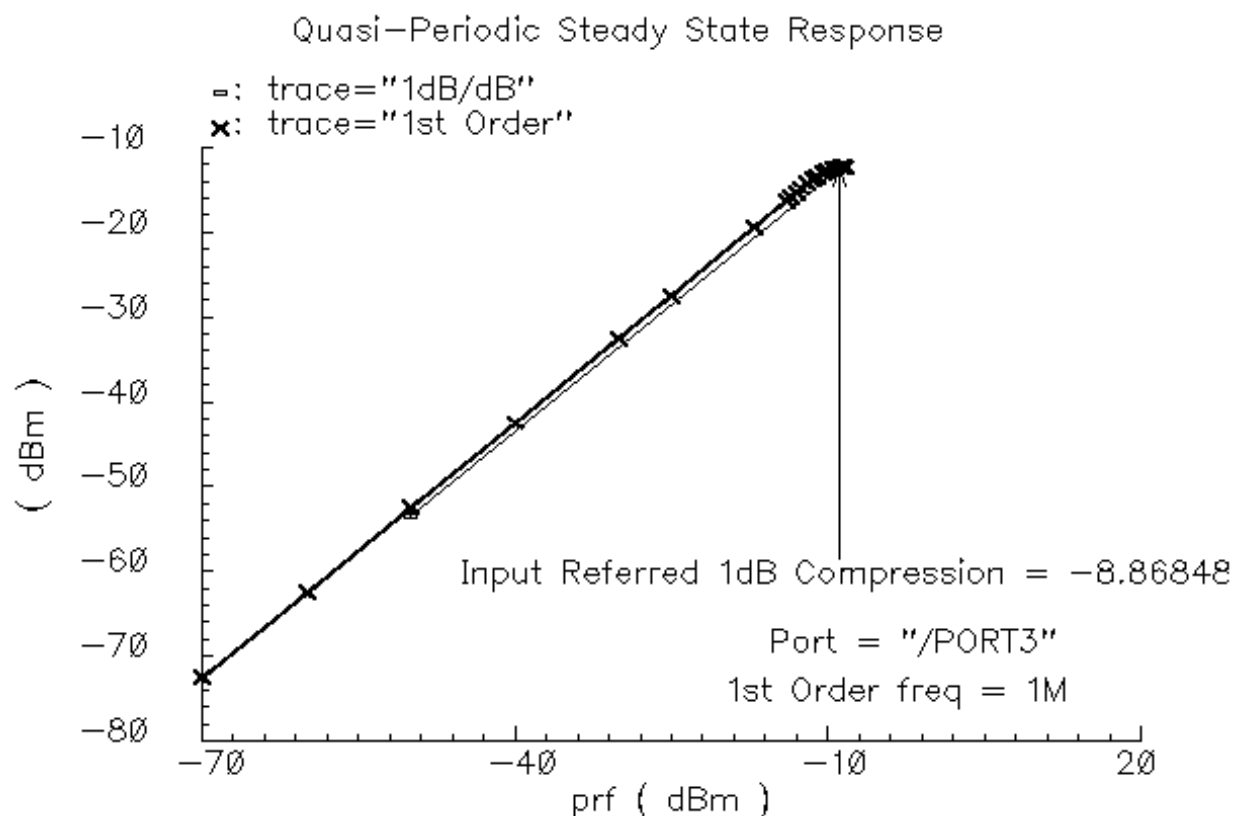

1. To plot IP3, click *qpac* analysis. Select *IPN Curves*. Select *Variable sweep* and choose -30 dB for the *prf* extrapolation.

Note: If the first extrapolation point you select is not in the linear range of the IM1 and IM3 curves, you might want to reset the extrapolation point later.

2. To plot the third order input referred intercept point, set the first order harmonic to (-1 0) or 1.1 MHz, and the third order harmonic to (1 -2), or 0.9 MHz. Since the mixer is down-converting to the baseband, the first harmonic is calculated as:

Mixer Design Using SpectreRF

Mixer Design Measurements

$$f(\text{small signal}) - f(\text{LO}) = 5.0011\text{GHz} - 5\text{GHz} = 1.1\text{MHz}$$

The third harmonic is at 0.9 MHz or -0.9 MHz depending on the *freqaxis* you selected in the QPAC *Options* form. Select *PORT3* on the schematic. The third order input referred intercept point is calculated and curves of harmonics versus *prf* are presented as shown at Figure 1-15.

Note: If necessary, you might set *errpreset = conservative* accuracy when you set up the QPSS analysis. For your first attempt, when you do not know the exact location of the linear region for IM3 and IM1, you might use *errpreset = moderate* or even *errpreset = liberal*. When you know the power level, a single point *errpreset = conservative* simulation might be much more accurate and less time-consuming.

Figure 1-15 IP3 Measurements Using QPAC Analysis

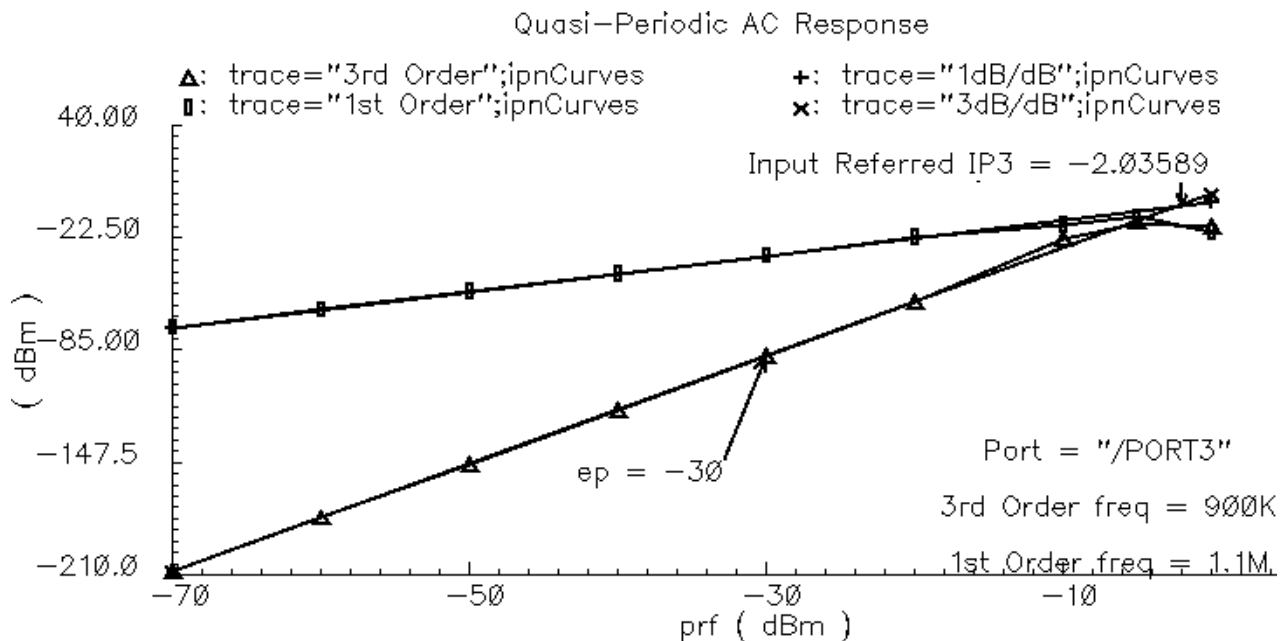

Note: The QPAC analysis is only able to compute IP3. You cannot use QPAC analysis to compute IP5 and IP7. To get higher order intermodulation curves, apply the LO and two moderate RF input tones in a single QPSS analysis.

Port-to-Port Isolation Among RF, IF and LO Ports (PSS and Swept PAC)

The isolation required between a mixer's ports depends on the circuit and the architecture of the product. Isolation is critical for the mixer to function properly.

Mixer Design Using SpectreRF

Mixer Design Measurements

You can combine PAC and PXF analyses to produce transfer functions from different ports to each other. One suggested configuration might be to set up

- A PAC analysis with nonzero *pacmag* parameter at the signal input (the RF port)
- A PXF analysis with the IF port as the output probe

This example uses *pacmag* = 1 for simplicity.

Testbench, Analyses and Simulation:

1. Set up the Mixer Testbench, the PSS analysis and the PAC analysis as described in [“Voltage Conversion Gain Versus RF Frequency \(PSS and Swept PAC\)”](#) on page 11.
2. Set up a PXF analysis similar to the PXF analysis described in [“Voltage Conversion Gain Versus RF Frequency \(PSS and Swept PXF\)”](#) on page 13. Change the PXF analysis to measure output over a frequency range that includes both the RF input frequency and the LO frequency.
3. Run the simulations.

Display/Data Analysis:

RF-to-LO feedthrough affects the local oscillator by letting strong interferers at the input pass to the LO. Measure RF-to-LO feedthrough using the PAC analysis results.

Click *Results—Direct Plot—Main Form*. Click *pac* analysis. Select the LO port as the output instance and select *-1* in *Output Harmonics* to represent the down-converted RF signal.

Mixer Design Using SpectreRF

Mixer Design Measurements

The response at the IF frequency range displays as in Figure 1-16.

Figure 1-16 The RF-to-LO Feedthrough Using PAC Analysis

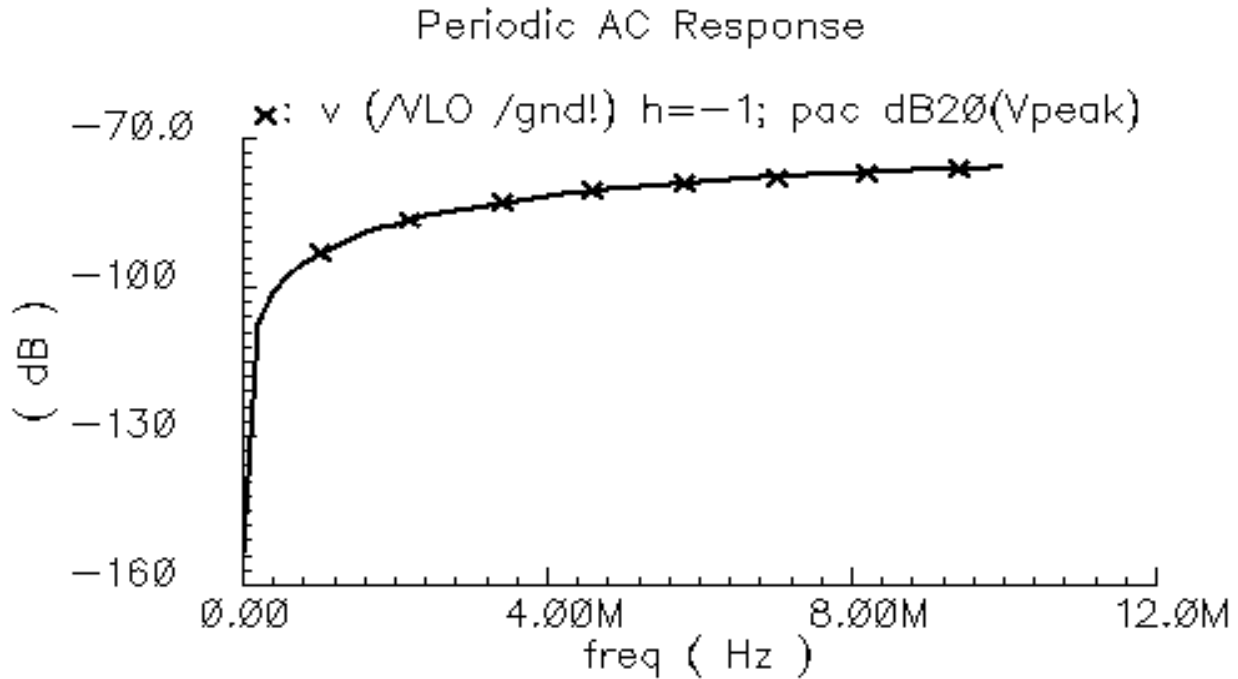

RF-to-IF feedthrough might create an even-order distortion problem for homodyne receivers. Measure RF-to-IF feedthrough using the PAC analysis results with two simple changes.

Click *Results—Direct Plot—Main Form*. Click *pac* analysis. This time, select *0* in *Output Harmonics* and select the IF port.

Mixer Design Using SpectreRF

Mixer Design Measurements

RF-to-IF feedthrough is plotted as in Figure 1-17.

Figure 1-17 The RF-to-IF Feedthrough Using PAC Analysis

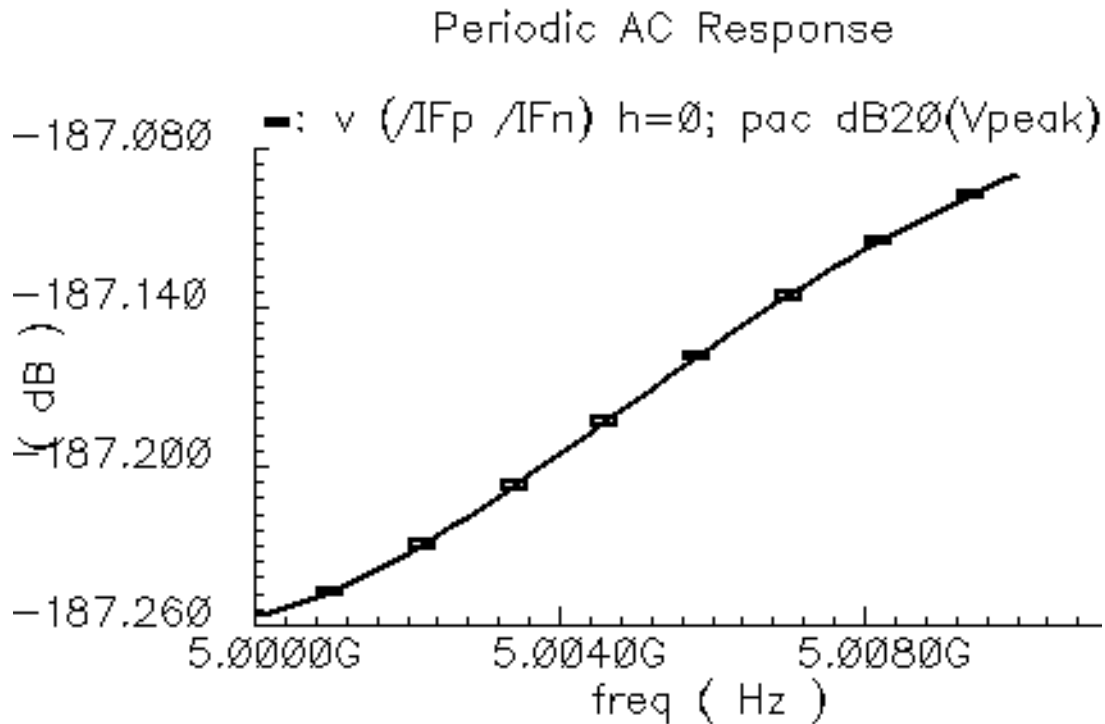

To avoid desensitizing the stage following the mixer with high-level LO signal feedthrough to the output, measure LO-to-IF isolation. Use the results of the PXF analysis with the IF port as output to measure the level of isolation.

In the Direct Plot form for the PXF analysis, select the LO port as the output, and select the *0 Harmonic* to represent LO feedthrough.

Mixer Design Using SpectreRF

Mixer Design Measurements

LO-to-IF Feedthrough is shown in Figure 1-18.

Figure 1-18 The LO-to-IF Feedthrough Using PXF Analysis

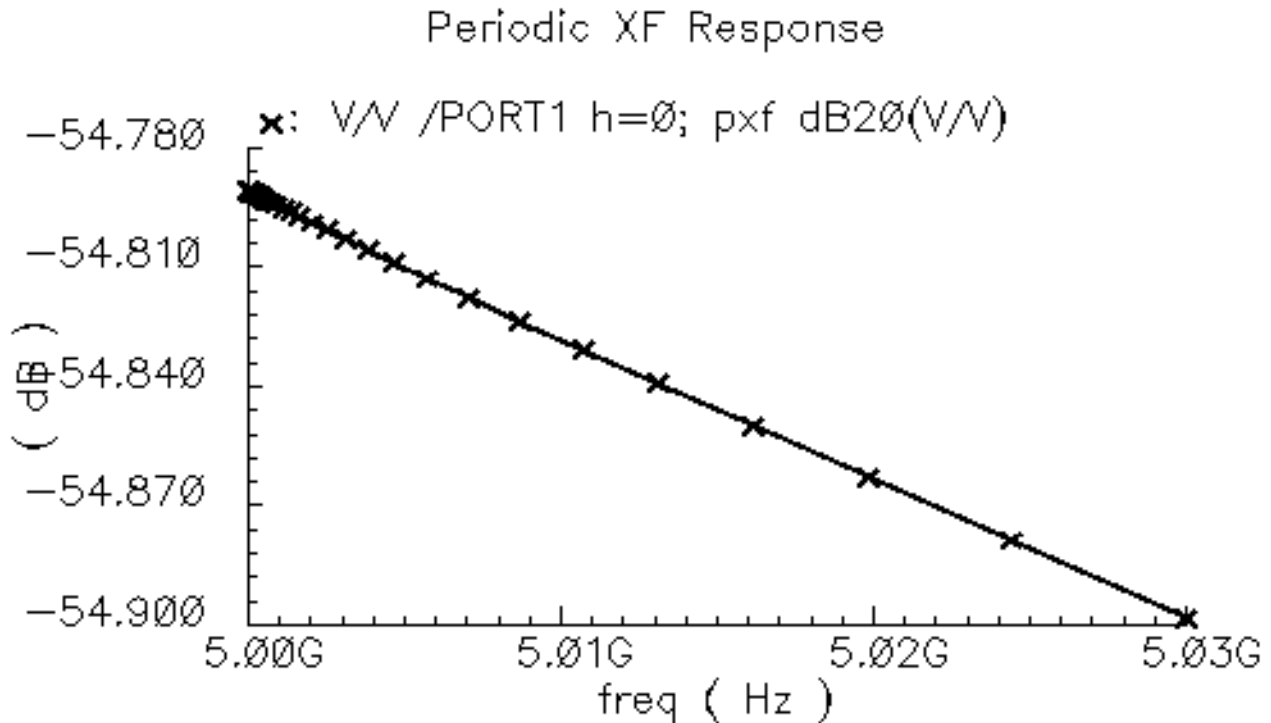

You can measure LO-to-RF feedthrough using a similar PXF analysis, with output set to the RF port or by using a PSP analysis (S13 from “S-Parameters (PSS and PSP)” on page 18). LO-to-RF feedthrough affects the functionality of LNAs and antennas.

Mixer Performance with a Blocking Signal (QPSS, QPAC, and QPNoise)

Large interfering signals are called *blockers*. Blocking signals reduce the mixer’s gain and deteriorate the mixer’s noise performance. As such, you need to measure the gain and noise of a mixer in the presence of a blocking signal. All major communication standards include blocking requirements for both mobile and base stations. The requirements use several in-band and multiple out-of-band blocking signals.

Because a mixer has both signal and LO inputs, you should use the multi-tone large signal QPSS analysis for these measurements. Follow the QPSS analysis with QPAC and QPNoise analyses to measure gain and NF variations versus the level of the interfering signal. In the QPSS analysis, model the blocker as a moderate tone.

Mixer Design Using SpectreRF

Mixer Design Measurements

Testbench:

Mixer testbench in Figure [1-2](#).

Simulation/Analyses:

1. Set up the QPSS and QPAC analyses.

Set up the QPSS and QPAC analyses as described in [“Intermodulation Distortion and Intercept Points \(Swept QPSS and QPAC\)”](#) on page 25.

Represent the blocking signal by setting the moderate tone frequency $frf = 5.003$ GHz. Represent a small-signal RF input by setting a fixed value for the $pacm$ parameter. For example, in this example $pacm = -30$ dB. In the QPSS analysis, sweep the parameter prf from -50 dB to -8 dB.

Set the QPAC *input frequency* = 5.001 GHz and *Sweep type* = *absolute*.

2. Set up the QPNoise analysis.

Use a 1 MHz frequency point and *Maximum clock order* = 10. Set *Output probe* as *PORT3* and *Input source* as *PORT0*. Use the *Reference sideband* as (1 0) to represent a downconverted RF signal relative to the IF output signal, $1 \text{ MHz} + 1 * f(\text{LO}) = f(\text{RF})$.

3. Run the simulations.

Display/Data Analysis:

Calculate gain from the QPAC analysis as shown in Figure [1-19](#). Calculate Noise Figure from the QPNoise analysis as shown in Figure [1-20](#).

In the QPAC analysis, select *Instance with 2 terminals* and set *Sweep type* to *variable*. Select the *Output harmonic* as (-1 0) at 1 MHz to get the small-signal response from the RF small-signal source. Select *PORT3* and plot using *db20* for a better presentation. Set $pacmag = 1$ V to plot conversion gain. Otherwise, you get the response from the small-signal stimuli versus the growing power of the blocker.

Mixer Design Using SpectreRF

Mixer Design Measurements

Figure 1-19 Blocker Effect on Voltage Gain

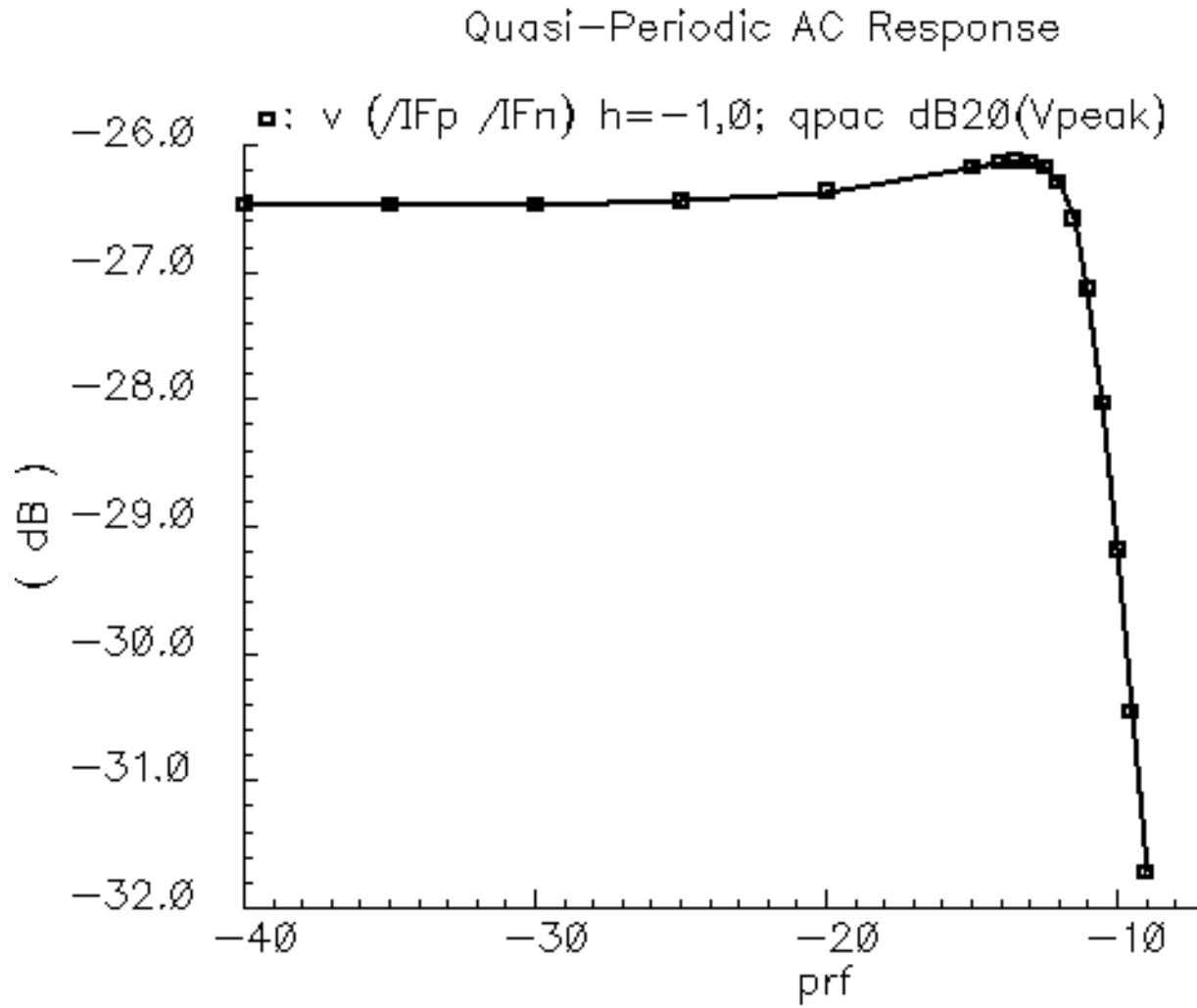

Mixer Design Using SpectreRF

Mixer Design Measurements

Figure 1-20 Blocker Effect on Noise Figure

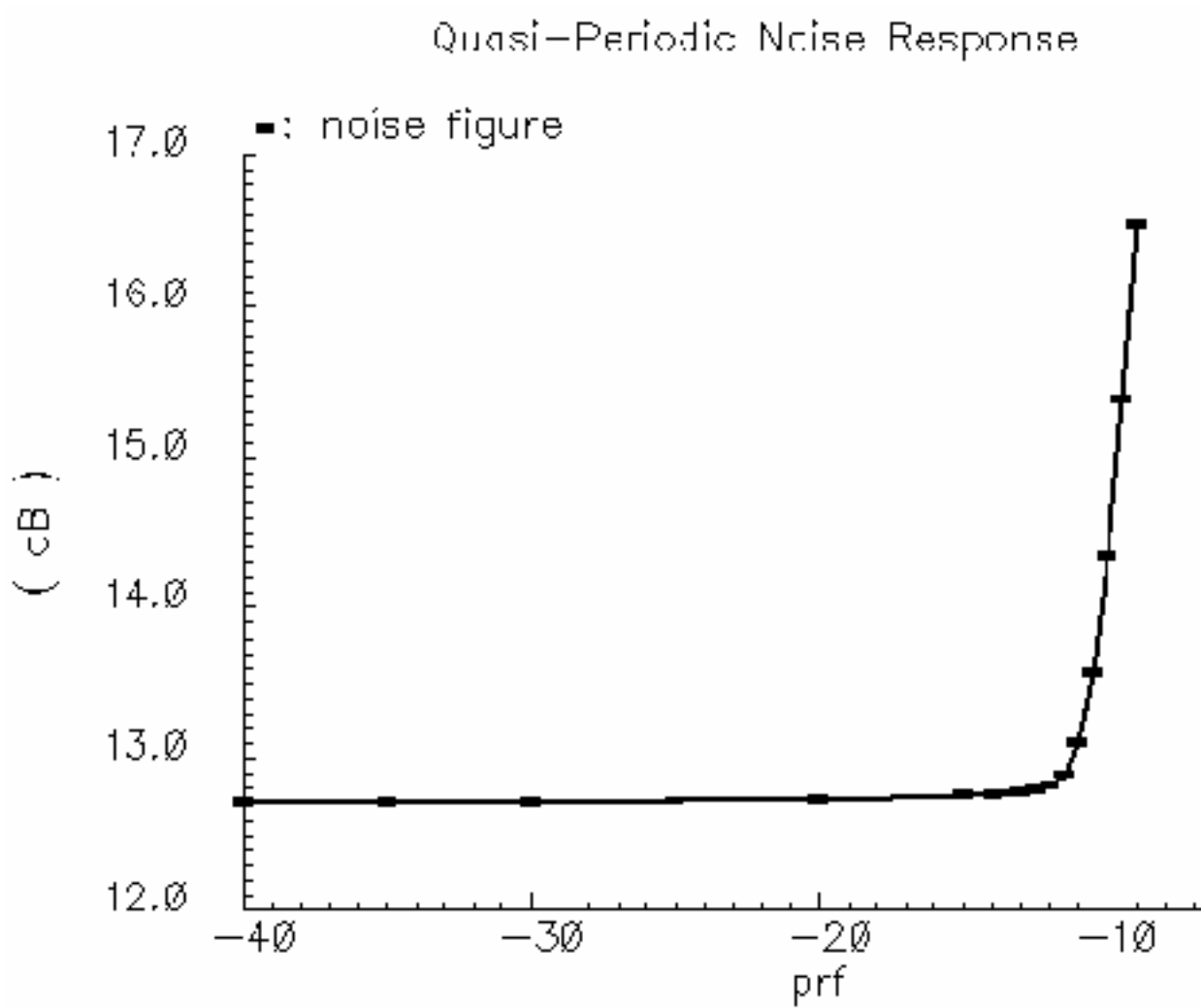

Mixer Design Using SpectreRF

Mixer Design Measurements
